

# TFA01M

ELECTRONIC THERMOSTAT FOR FAN-COILS  
WITH 0..10V OUTPUT



Via del Commercio, 9/11 36065 Mussolente (VI)  
Tel.: +39.0424.567842 - Fax.: +39.0424.567849 - <http://www.seitron.it> - e-mail: [info@seitron.it](mailto:info@seitron.it)

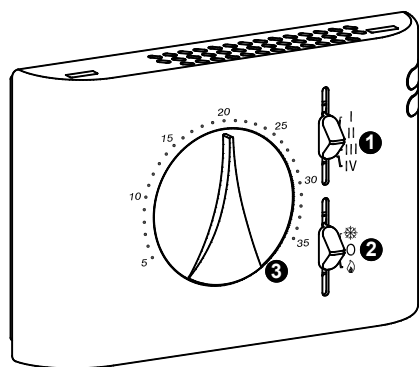

Fig. 1

## LEGEND

- 1 Engine speed selector
- 2 Three-position selector: cooling /OFF / heating
- 3 Room temperature adjustable knob

## OVERVIEW

This device is an electronic thermostat for temperature regulation in environments heated or cooled with fan-coil units with 0..10V engine, in two or four pipes systems. Power supply is 230V~ or 24V~.

This device features an outlet to connect an external temperature probe 'SA' and one to connect a bimetallic thermostat functioning as 'cut-off thermostat' (TM).

Using the mechanical pins the angle of rotation of the knob can be reduced.

## OPERATION

The thermostat controls available to the user are two selectors and a knob.

### ENGINE SPEED SELECTOR (1 of Fig. 1)

With this 4-speed selector you can choose a fixed fan-coil engine activation speed.

### COOLING / HEATING SELECTOR (2 of Fig. 1)

This three-position selector can be used to switch ON the thermostat (in cooling or heating mode) or turn it OFF, as in the description below:

- **Cooling mode:**  
Position the selector on the ☼ symbol to enable the cooling mode.
- **Heating mode:**  
Position the selector on the ☀ symbol to enable the heating mode.
- **OFF Mode:**  
Position the selector on the 0 symbol to switch OFF the device.

### KNOB (3 of Fig. 1)

This adjustment knob is used to set the temperature at which the desired temperature will be checked, which can be between +5°C .. +35°C.

### KNOB ROTATION LIMITATION

It is possible to limit the rotation range for the set-point knob by following these steps:

1. Extract the knob as indicated in 2 in the "INSTALLATION" paragraph.
2. Position the mechanical pins as shown in the example in Fig. 6 (E). The field of rotation is, in this way, reduced as in the arc shown in (F) of Fig. 6.

## POWER SUPPLY

The device can be put to 230V~ or to 24V~.

The thermostat is set by default at 230V~, with the jumper in position J2. To select the 24V~ power supply it is necessary to move the jumper J2 in J1 position.

As it can be seen in the wiring diagrams the power supply terminals are L and N. If the power supply is set at 230V~ it is important to respect the line and neutral.

## SYSTEM TYPE CONFIGURATION

Properly acting on the J3 jumper, it is possible to set the thermostat on two or four pipes functioning mode.

### Four-pipe system w/ two valves

If the thermostat is set on functioning with four pipes (jumper J3 in position B), two valves outputs will be available (☀ or ☼) activated as follows:

#### Selector set on Heating mode

The valve output ☀ will be activated when the room temperature falls below the set point selected via the knob.

#### Selector set on Cooling mode

The valve output ☼ will be activated when the room temperature rises above the set point selected via the knob.

### Two-pipe system w/ one valve

If the thermostat has been configured for a two-pipe system, (jumper J3 in position A), only one valve output will be available activated as follows:

#### Selector set on Heating mode

The valve output (connected to the terminal n. 4) will be activated when the room temperature falls below the set point selected via the knob.

#### Selector set on Cooling mode

The valve output (connected to the terminal n. 4) will be activated when the room temperature rises above the set point selected via the knob.

## CUT-OFF THERMOSTAT

The "cut-off thermostat" function (TM) allows to forbid the fan-coil operation when, in heating mode, the supply water is not hot enough.

To engage this function it is necessary to move the jumper J4 in position B and connect a bimetallic thermostat to the terminal number 9.

In case of doubts on the kind of bimetallic thermostat to connect feel free to contact the manufacturer.

The thermostat is by factory-default set with the cut-off thermostat NOT active.

## VALVES OUTPUT SETTING

The thermostat is by factory default prepared with thermostatically active valves output (jumper J5 in position A, for the cooling valve output, and jumper J6 in position A, for the heating valve output).

With the thermostatically active valve output, the valve closes when the environmental temperature picked up by the internal sensor or by the remote sensor reaches the temperature set by the knob.

By setting properly the jumper J5 and/or J6, it is possible to set the thermostat to function with the valves outputs not thermostatically active (jumper J5 in position B, for the cooling valve output, and jumper J6 in position B, for the heating valve output).

By the not thermostatically active valves output, the valve is always open, independently from the temperature set by the knob and from the temperature picked up by the internal sensor or by the remote sensor.

## ENGINE 0..10V OUTPUT SETTING

The thermostat is by factory default prepared with thermostatically active engine output (jumper J7 in position A, in cooling mode, and jumper J8 in position A, in heating mode).

With the thermostatically active engine output, the engine switches OFF when the environmental temperature picked up by the internal sensor or by the remote sensor reaches the temperature set by the knob.

Setting properly the jumper J7 and/or J8, it is possible to set the thermostat to operate with the engine output not thermostatically active (jumper J7 in position B, in cooling mode, and jumper J8 in position B, in heating mode).

By the not thermostatically active engine output, the engine is always active, independently from the temperature set by the knob and from the temperature picked up by the internal sensor or by the remote sensor.

## INTERNAL SENSOR / EXTERNAL SENSOR

This thermostat comes factory set for the operation with an internal sensor. In case the installation requires a remote sensor set properly the J9 jumper to the position B and connect an NTC probe featuring 10 K $\Omega$  at 25°C to the terminals number 10 and 11 or, alternatively, to the RS connector. In case of doubts about the sensor type please contact the manufacturer.

## ENGINE SPEED SETTING

The device is prepared with two internal trimmers, VMIN and VMAX, to narrow the fan-coil engine's minimum and maximum speed ECM 0-10V.

VMIN: sets the minimum speed of the engine in relation with position I of the engine speed selector in the 0 .. 3V range. The thermostat has a factory-default VMIN set to 1,5V.

VMAX: sets the maximum speed of the engine in relation with position IV of the engine speed selector in the 7 .. 10V range. The thermostat has a factory-default VMAX set to 8,5V.

Note: the intermediate speeds (position II and III of the engine speed selector) are automatically regulated in relation to VMIN and VMAX settings.

The thermostat has a factory-default intermediate values of 3,5V and 5,5V.

## TECHNICAL FEATURES

Power supply:	24/230V~ 50/60Hz
Absorption:	7,7VA
Internal Sensor Type:	NTC10K $\Omega$ @ 25°C $\pm$ 1%
Temperature Setting Range:	5°C .. 35°C
Precision:	$\pm$ 1°C
Resolution:	2°C
Hysteresis:	0,5°C
Remote Sensor (optional):	NTC10K $\Omega$ @25°C $\pm$ 1%

### Proportional output:

Signal range:	0 .. 10V=
Signal precision:	$\pm$ 0,26
Minimum impedance:	
Engine input:	1000 Ohm

Relay contacts ratings: 2x3(1)A 250V~ SPST (voltage free)

Protection rating: IP 30  
Type of action: 1  
Pollution degree: 2

Overvoltage category: II  
Class of protection against electric shocks: II $\square$   
Rated impulse voltage: 2500V  
Tracking Index (PTI): 175  
Number of manual cycles: 1.000  
Number of automatic cycles: 100.000  
Software class: n.a.  
EMC test voltage: 230AC  
EMC test current: 38mA

Distances tolerances fault

Mode 'short' exclusion:  $\pm$  0,15 mm  
Ball pressure test temperature: 75°C  
Operating temperature: 0°C..40°C  
Storage temperature: -10°C.. +50°C  
Humidity limits: 20% .. 80% RH (non-condensing)

Enclosure: Material: ABS V0 self-extinguishing  
Color: Signal White (RAL 9003)  
Dimensions: 120 x 80 x 38 mm (W x H x D)  
Weight: ~ 183 gr.

## CLASSIFICATION ACCORDING TO REGULATION 2013.811.CE

Class: V  
Contribution to energy efficiency: 3

## WARRANTY

In the view of a constant development of their products, the manufacturer reserves the right for changing technical data and features without prior notice. The consumer is guaranteed against any lack of conformity according to the European Directive 1999/44/EC as well as to the manufacturer's document about the warranty policy. The full text of the warranty is available on request from the seller.

## INSTALLAZIONE / INSTALLATION

### ⚠ ATTENZIONE

- Per una corretta regolazione della temperatura ambiente si consiglia di installare il termostato a circa 1,5 m dal pavimento, lontano da fonti di calore, correnti d'aria o da pareti particolarmente fredde (ponti termici). Se si usa una sonda a distanza la nota va applicata alla sonda e non al termostato.
- Per i collegamenti della sonda usare cavi di sezione minima 1,5 mm<sup>2</sup> e di lunghezza massima di 25 m. Non passare i cavi della sonda nelle canaline della rete.
- Collegare l'apparecchio alla rete di alimentazione tramite un interruttore onnipolare conforme alle norme vigenti e con distanza di apertura dei contatti di almeno 3 mm in ciascun polo.
- L'installazione ed il collegamento elettrico del dispositivo devono essere eseguiti da personale qualificato ed in conformità alle leggi vigenti.
- Prima di effettuare qualsiasi collegamento accertarsi che la rete elettrica sia scollegata.

### ⚠ WARNING

- To adjust properly the room temperature we advise to install the thermostat at 1,5 m from the floor, far from heat sources, airstreams or particularly cold walls (thermal bridges). When the remote sensor is used in conjunction with the thermostat, then this note must be applied to the remote sensor itself.
- For remote versions all wirings must be made using wires with 1,5 mm<sup>2</sup> minimum cross section and not longer than 25 m. Do not use same duct for signal wires and mains.
- The appliance must be wired to the electric mains through a switch capable of disconnecting all poles in compliance with the current safety standards and with a contact separation of at least 3 mm in all poles.
- Installation and electrical wirings of this appliance must be made by qualified technicians and in compliance with the current standards.
- Before wiring the appliance be sure to turn the main power off.

- 1** Sganciare la piastra attaccata alla base del termostato spingendola verso sinistra e facendo così sganciare i dentini indicati in Fig. 2.

Release the plate attached to the thermostat base by pushing it to the left. This releases the teeth shown in Fig. 2.

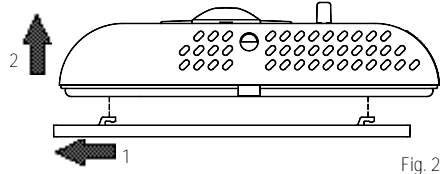

Fig. 2

- 2** Spostare entrambi gli slider completamente in basso e posizionare la manopola su 20°C; quindi sollevare la manopola facendo leva con un cacciavite nell'apposito invito, indicato dalla freccia in Fig. 3, facendo attenzione a non rigare la calotta.

Move both sliders all the way down and position the knob at 20°C; lift the knob using a screwdriver as shown by the arrow in Fig. 3, being careful not to scratch the cover.

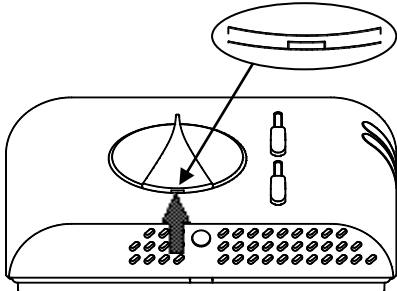

Fig. 3

- 3** Spingere, con l'aiuto di un cacciavite, la linguetta plastica situata nella feritoia in basso fino a sollevare leggermente la calotta (Fig. 4).

Push the plastic tab in the lower slot using a screwdriver, slightly lifting the cover (Fig. 4).

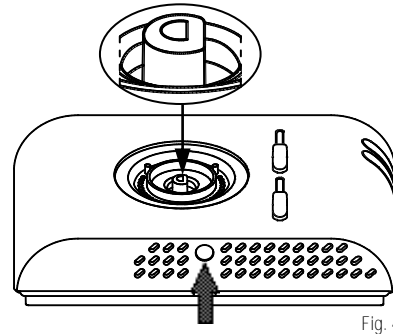

Fig. 4

- 4** Ruotare la calotta esercitando una leggera pressione fino ad estrarla completamente (Fig. 5).

Turn the cover, while pressing it slightly, until it is fully extracted (Fig. 5).

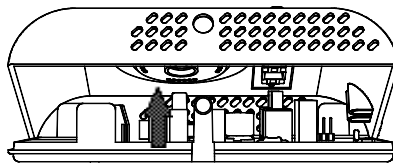

Fig. 5

- 5** Prelevare i cavalieri meccanici dalla base del termostato ed inserirli opportunamente nella calotta in modo da ridurre il campo di rotazione della manopola (vedere l'esempio di Fig. 6 e leggere il paragrafo 'blocco manopola'). Il terzo cavaliere parcheggiato in alto è di scorta.

Remove the mechanical pins from the thermostat base and insert them in the cover to reduce the knob's field of rotation (see example in Fig. 6 and read the "knob lock" paragraph). The third pin at the top is a spare.

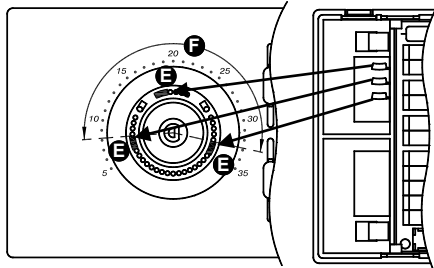

Fig. 6

- 6** Fissare la piastra alla parete tramite le due sedi per viti con interasse 60 mm oppure 85 mm (utilizzare le viti e/o i tasselli in dotazione) facendo passare i fili tramite le aperture rettangolari.

Fix the plate to the wall, using the two screw seats with centre distances of 60 mm or 85 mm (use the supplied wall plugs and/or screws). Pass the wires through the rectangular openings.

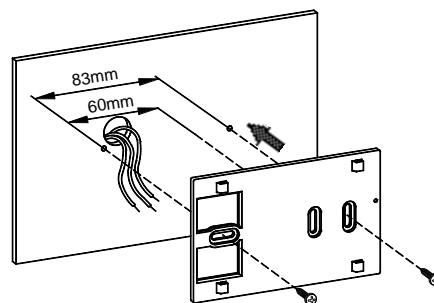

Fig. 7

- 7** Agganciare la base del termostato alla piastra a muro (facendo passare i fili tramite le aperture rettangolari) facendo dapprima coincidere i fori della base con gli appositi dentini della piastra a muro e successivamente esercitare sulla base una pressione verso il lato sinistro fino a far scattare i dentini plastici della piastra (Fig. 8).

Fissare la base del termostato alla piastra a muro utilizzando la vite in dotazione.

Connect the thermostat base to the wall plate (pass the wires through the rectangular openings). Align the base holes with the special wall plate teeth, then press the base to the left until the plate's plastic teeth click (Fig. 8).

Fix the thermostat base to the wall with the supplied screws.

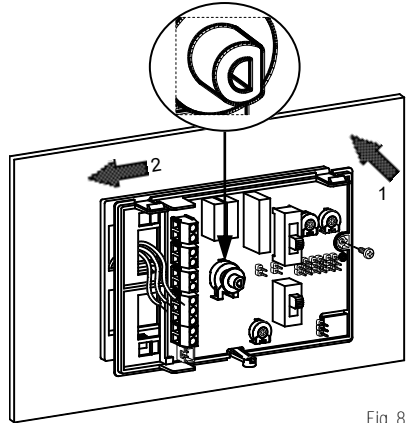

Fig. 8

### DISPOSIZIONE INTERNA COMPONENTI COMPONENTS' INTERNAL DISPOSITION

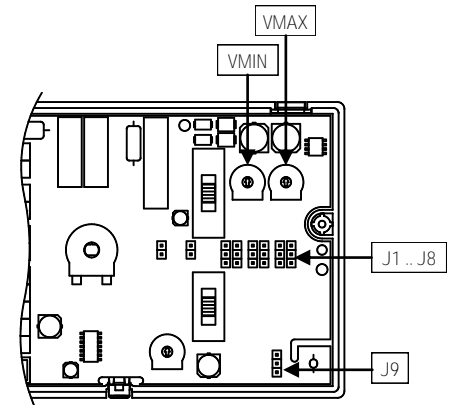

Fig. 9

### 8 REGOLAZIONE VELOCITA' MOTORE REGOLAZIONE VELOCITA' MOTORE

VMIN: velocità minima del motore associata al selettore in posizione I.

1,5  
0 VMIN 3  
Regolabile nel range 0 .. 3V (Default 1,5V).  
Adjustable in 0 .. 3V range (Default 1,5V).

VMAX: velocità massima del motore associata al selettore in posizione IV.

8,5  
7 VMAX 10  
Regolabile nel range 7 .. 10V (Default 8,5V).  
Adjustable in 7 .. 10V range (Default 8,5V).

## 9 IMPOSTAZIONI JUMPER / JUMPER SETTINGS

### J1 - J2: ALIMENTAZIONE / POWER SUPPLY

J1 J2 Alimentazione a 24V ~  
Power supply 24V ~  
24V 230V

J1 J2 Alimentazione a 230V ~ (Default)  
Power supply 230V ~ (Default)  
24V 230V

### J3: CONFIGURAZIONE IMPIANTO / SYSTEM SETTINGS

J3 B 2 Tubi e 1 valvola (Default)  
A 2 Tubes and 1 valve (Default)

J3 B 4 Tubi e 2 valvole  
A 4 Tubes and 2 valves (Default)

### J4: SELEZIONE TERMOSTATO DI MANDATA / SUPPLY PIPE THERMOSTAT

J4 B Disabilitata (Default)  
A Deactivated (Default)

J4 B Attivata  
A Active

### J5: IMPOSTAZIONE USCITA VALVOLA RAFFRESCAMENTO / COOLING VALVE OUTPUT SETTING

J5 B Termostata (Default)  
A Thermostatically active (Default)

J5 B Non termostata  
A Not thermostatically active

### J6: IMPOSTAZIONE USCITA VALVOLA RISCALDAMENTO / HEATING VALVE OUTPUT SETTING

J6 B Termostata (Default)  
A Thermostatically active (Default)

J6 B Non termostata  
A Not thermostatically active

### J7: IMPOSTAZIONE USCITA MOTORE 0.10V RAFFRESCAMENTO / COOLING ENGINE OUTPUT SETTING

J7 B Termostata (Default)  
A Thermostatically active (Default)

J7 B Non termostata  
A Not thermostatically active

### J8: IMPOSTAZIONE USCITA MOTORE 0.10V RISCALDAMENTO / HEATING ENGINE OUTPUT SETTING

J8 B Termostata (Default)  
A Thermostatically active (Default)

J8 B Non termostata  
A Not thermostatically active

### J9: SELEZIONE SONDA INTERNA O ESTERNA / INTERNAL / EXTERNAL PROBE SELECTION

J9 B Sonda interna (Default)  
A Internal probe (Default)

J9 B Sonda esterna  
A External probe

## 10 COLLEGAMENTI ELETTRICI / ELECTRIC WIRINGS

--- : Isolamento rinforzato / Reinforced insulation

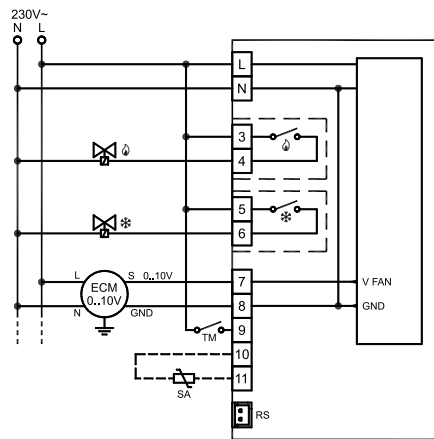

Fig. 10: Schema di collegamento per un impianto a 4 tubi con due valvole ON/OFF, alimentato a 230V~ e motore a 230V~.

Wiring diagram for a 4-pipe system with two on/off valves powered with 230V~ and engine to 230V~.

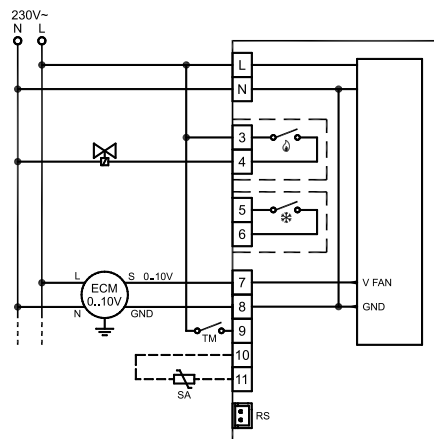

Fig. 11: Schema di collegamento per un impianto a 2 tubi con una valvola ON/OFF alimentato a 230V~ e motore a 230V~.

Wiring diagram for a 2-pipe system with an ON / OFF valve 230V~ and engine to 230V~.

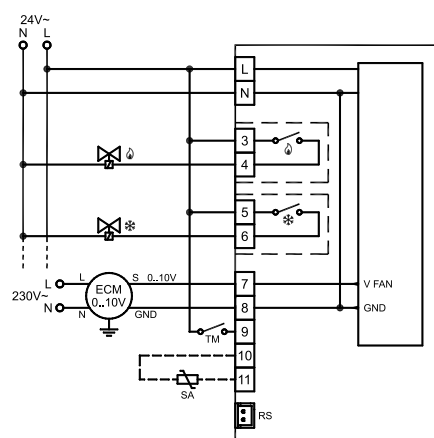

Fig. 12: Schema di collegamento per un impianto a 4 tubi con due valvole ON/OFF, alimentato a 24V~ con motore a 230V~.

Wiring diagram for a 4-pipe system with two on / off valves powered with 24V~ and engine to 230V~.

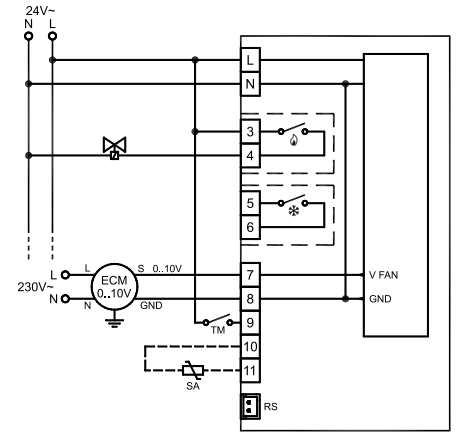

Fig. 13: Schema di collegamento per un impianto a 2 tubi con una valvola ON/OFF, alimentato a 24V~ con motore a 230V~.

Wiring diagram for a 2-pipe system with an ON/OFF valve powered with 24V~ and engine to 230V~.

- 11** Richiudere il termostato eseguendo le seguenti operazioni:  
Posizionare i due dentini della parte superiore della calotta negli appositi intagli e lasciare entrambi gli slider in basso. Ruotare la calotta facendo in modo che gli slider coincidano con i relativi commutatori e spingere verso l'interno la linguetta plastica posta sulla parte inferiore della base (indicata dalla freccia in Fig. 14) ed esercitare una pressione che faccia scattare la linguetta plastica di fissaggio all'interno del foro sul lato inferiore della calotta. Quindi verificare la corretta corsa degli slider.

Perform the following operations to reclose the thermostat:  
Position the two teeth from the top of the cover into the specific slots and leave both sliders at the bottom. Turn the cover making sure the sliders coincide with the relative switches, push the plastic tab on the lower part of the base inwardly (see the arrow in Fig. 14) and press it so that the plastic fixing tab inside the special hole, at the bottom of the cover, clicks. Check the sliders' correct stroke.

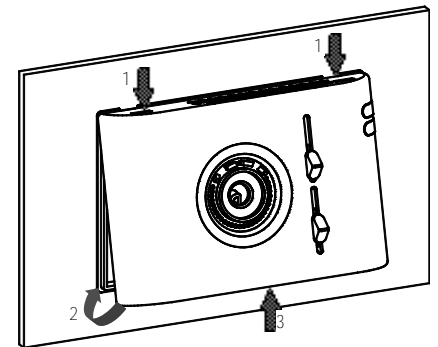

Fig. 14

- 12** Posizionare la manopola su 20°C ed inserirla sulla calotta.  
Place back the knob on 20°C and insert on the cover.

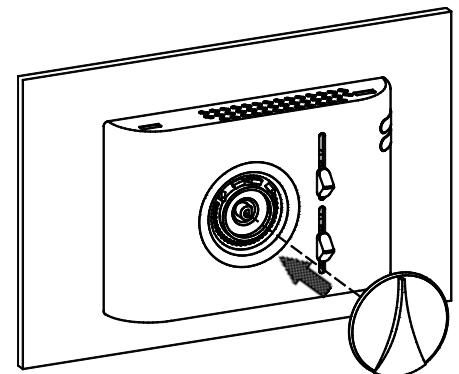

Fig. 15